

10-Speed Transmissions A Ratio Direct

This document includes information on the following Rockwell transmission models:

- RM10-115A*
- RM10-125A*
- RM10-135A*
- RM10-145A*
- RM10-155A*

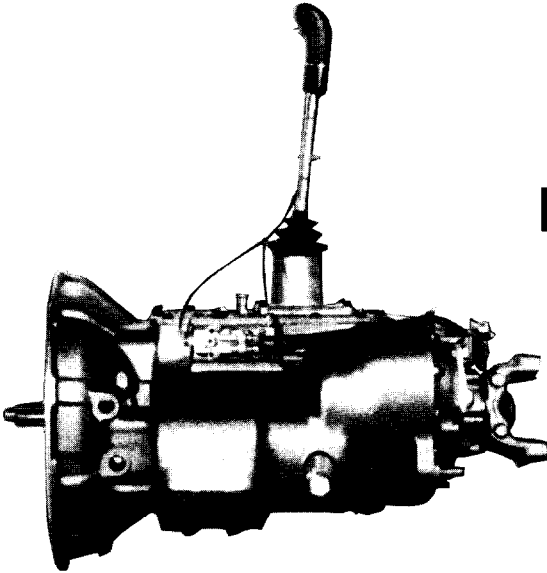

Model Number and Designations

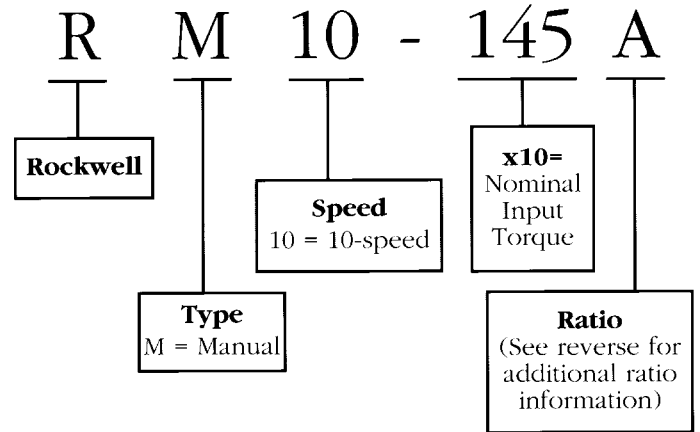

*Available with Rockwell's Engine Synchro Shift™ (ESS) system. For ESS transmission models, replace the "M" in the above model numbers with an "S".

Features	Benefits
<ul style="list-style-type: none"> • 1:1 Direct drive to gear with 34% step 	<ul style="list-style-type: none"> • Optimal fuel efficiency in direct top gear
<ul style="list-style-type: none"> • Deep first and second gear, with 35% step and overall ratio of 15.02 in forward, 16.71 in reverse 	<ul style="list-style-type: none"> • Improved startability and maneuvering speed
<ul style="list-style-type: none"> • Full line of torque ratings from 1150 to 1550 lb.-ft. 	<ul style="list-style-type: none"> • Optimum match with today's high torque, low RPM engines
<ul style="list-style-type: none"> • Close steps and ratios 	<ul style="list-style-type: none"> • Smooth, more precise shift feel
<ul style="list-style-type: none"> • Fine mesh gear faces and improved tooth contact area 	<ul style="list-style-type: none"> • Low gear noise and vibration levels for enhanced driver comfort
<ul style="list-style-type: none"> • Larger diameter mainshaft 	<ul style="list-style-type: none"> • Increased reliability by helping to resist shockloads, even when used with today's high torque engines
<ul style="list-style-type: none"> • Lighter installed weight 	<ul style="list-style-type: none"> • Potential overall weight savings
<ul style="list-style-type: none"> • Soft-molded, ergonomic shift knob 	<ul style="list-style-type: none"> • Increased driver comfort and convenience
<ul style="list-style-type: none"> • Available with optional Shift-n-Cruise™ feature 	<ul style="list-style-type: none"> • Makes using cruise control functions easier for drivers
<ul style="list-style-type: none"> • Optional advanced shift system technologies 	<ul style="list-style-type: none"> • Eases driver workload while helping reduce overall operating costs

Specifications: 10-Speed A Ratio Direct Transmissions

Ratios and Steps		
Gear	Ratio	% Step
1	15.02	35
2	11.14	35
3	8.26	37
4	6.02	34
5	4.48	34
6	3.35	35
7	2.48	35
8	1.84	37
9	1.34	34
10	1.00	
Overall-Fwd.	15.02	
Overall-Rev.	16.71	
Low-Rev.	16.71	
High-Rev.	3.73	

Step Chart

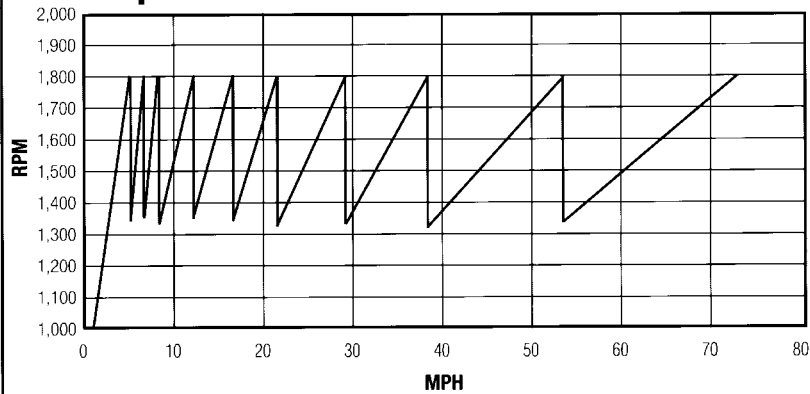

Shift Pattern

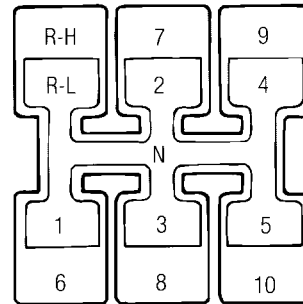

Model	Weight* (lbs)	Torque Rating (lb-ft)	PTO Speed (% of engine speed)
RM10-115A	588	1,150	75.8
RM10-125A	588	1,250	75.8
RM10-135A	605	1,350	75.8
RM10-145A	605	1,450	75.8
RM10-155A	608	1,550	75.8

*Less bell housing, shift controls, output yoke and oil.
Weights are approximate.

Power Take-Off (all models)

Right side – 6 bolt, 45 tooth 6/8 pitch
Bottom – 8 bolt, 45 tooth 6/8 pitch

Available Options

- Forward shift bar housing
- Dip stick
- Magnetic drain plug
- Integral oil pump*
- Neutral switch port standard

*Oil pump standard on 1,550 lb-ft model.

SAE #1 Bell Housing Weight

Nodal Mount
Aluminum - 36 lbs.
Iron - 92 lbs.

Non-nodal Mount
Aluminum - 23 lbs.
Iron - 76 lbs.

SAE #2 Bell Housing Weight

Non-nodal Mount
Iron - 68 lbs.

Warranty

For warranty information, contact your Rockwell representative or see Rockwell publication SP-95108.

The entire family of Rockwell transmissions is an integral member of **Drivetrain Plus™ by Rockwell**, the industry's most complete drivetrain. For more information, call: **800-535-5560**.

